

PoleStar Smart-E Refrigeration Dryers

PSE 120 - 1800



Untreated compressed air is wet. 100% saturated as it leaves the compressor after-cooler, water vapour in the compressed air cools as it enters the air receiver and distribution piping, resulting in the formation of condensed liquid water and water aerosols. Wet compressed air leads to corrosion, the growth of micro-organisms and the formation of oily, acidic compressor condensate.

For a manufacturing facility reliant on compressed air for automation, these contaminants can directly impact safety, productivity and efficiency.

Compressed air treatment is therefore essential and for non-critical uses of compressed air, the refrigeration dryer is an ideal choice.

Refrigeration Dryers

Refrigeration dryers use a closed loop cooling system to lower the temperature of the compressed air to just above freezing, causing condensation of water vapour.

Most of the condensed liquid is then removed by an integral water separator and drained away. Prior to leaving the dryer, the compressed air is re-heated by the incoming compressed air to prevent condensation on the outside of the downstream distribution piping.

Refrigeration dryers should always be installed with general purpose and high efficiency coalescing filters and are an effective way to reduce water vapour, liquid water and water aerosols for general purpose compressed air applications.

Environmentally friendly Refrigeration Dryers, that work with Low GWP refrigerant in compliance with the requirements of the F-Gas Regulation (EU 517/2014), are the best choice to protect your investment, the climate and the environment.



Advantages

- Parker PoleStar Smart-E refrigeration dryers are developed around a state-of-the-art aluminium heat exchanger (SmartPack), with a large air/air heat exchanger to pre-cool the incoming compressed air and reduce the energy consumption
- The highly efficient SmartPack design, the electronic controlled HGV and the innovative micro-channel condensers result in a refrigerant circuit with lower absorbed power and about -40% volume of refrigerant versus traditional solutions
- The low pressure drops of the SmartPack design and the low absorbed power of the refrigerant circuit, make PoleStar Smart-E a highly competitive solution with lower operating costs vs comparable dryers
- Electronic controllers, including touch screen versions from PSE 220, providing indication of compressed air temperature, volt free alarm contact, service reminder, data log, alarm history and integral capacitive drain control
- LED unit status indicator from model PSE460 and HP / LP gauges on all models from PSE220
- Remote communication protocol, industry 4.0 ready, on all units; web server from model PSE220 and IoT ready from model PSE460
- The Energy Saving feature enables the dryers to save energy at partial load by cycling the refrigerant compressor while cooling the inlet air using the cold reserve stored in the SmartPack mass
- Variable speed fans from model PSE460, for more saving at partial load and increased condensation stability
- PoleStar Smart-E dryers utilise compliant scroll refrigeration compressors, offering longer life, lower noise and energy savings of up to 20% compared to piston alternatives
- All units designed for dual frequency 50/60Hz power supply. Installation flexibility thanks to reversible side of the inlet and outlet air connections on multi-cooler models (from PSE750)
- R513A refrigerant with Low GWP on all units, in line with the requirements of the F-Gas regulation, protects the environment and prevents from potential disruptions coming from refrigerants with higher GWP



ENGINEERING YOUR SUCCESS.

Dryer Performance

Dryer Models	Dewpoint (Standard)		Dewpoint (Option 1)		Dewpoint (Option 2)	
	°C	°F	°C	°F	°C	°F
PSE	+3	+37	+7	+45	+10	+50

Technical Data

Dryer Models	Min Operating Pressure		Max Operating Pressure		Min Operating Temperature		Max Operating Temperature		Max Ambient Temperature		Electrical Supply (Standard)	Electrical Supply (Optional)	Thread Connections	Noise Level
	bar g	psi g	bar g	psi g	°C	°F	°C	°F	°C	°F				dB(A)
PSE 120 - 1800	2	29	14	203	5	41	65	149	50	122	400V 3ph 50Hz / 460V 3ph 60Hz	N/A	BSPP & DIN Flange	<75

Flow Rates

Model	Pipe Size	Inlet Flow Rate at 50Hz				Absorbed Power at 50Hz kW	Inlet Flow Rate at 60Hz				Absorbed Power at 60Hz kW
		L/s	m³/min	m³/hr	cfm		L/s	m³/min	m³/hr	cfm	
PSE 120	2"	200	12	720	424	1.32	215	13	773	455	1.7
PSE 140	2"	233	14	840	494	1.32	252	15	907	534	1.7
PSE 180	2"	300	18	1080	636	1.51	323	19	1163	685	1.9
PSE 220	2 1/2"	367	22	1320	777	1.79	399	24	1435	845	2.2
PSE 260	2 1/2"	433	26	1560	918	2.05	474	28	1708	1005	2.5
PSE 300	2 1/2"	500	30	1800	1059	2.62	539	32	1941	1142	3.3
PSE 350	2 1/2"	583	35	2100	1236	3.22	624	37	2247	1323	4.0
PSE 460	DN100	767	46	2760	1625	3.22	835	50	3005	1769	3.9
PSE 520	DN100	867	52	3120	1836	4.55	941	56	3386	1993	5.6
PSE 630	DN100	1050	63	3780	2225	4.55	1172	70	4219	2483	5.6
PSE 750	DN150	1250	75	4500	2649	6.52	1381	83	4970	2925	8.0
PSE 900	DN150	1500	90	5400	3178	9.05	1655	99	5957	3506	11.0
PSE 1200	DN150	2000	120	7200	4238	9.05	2210	133	7956	4683	11.0
PSE 1500	DN200	2500	150	9000	5297	11.15	2760	166	9935	5848	13.6
PSE 1800	DN200	3000	180	10800	6357	13.45	3281	197	11812	6952	16.4

Stated flows are for operation at 7 bar (g) (102 psi g) with reference to 20°C, 1 bar (a), 0% relative water vapour pressure, 25 °C cooling air temperature, 35 °C air inlet temperature and +3°C pressure dew-point. All models supplied with low GWP refrigerant R513A.

For flows at other conditions, apply the correction factors shown below.

Product Selection & Correction Factors

For correct operation, compressed air dryers must be sized using for the maximum (summer) inlet temperature, maximum (summer) ambient temperature, minimum inlet pressure, required outlet dewpoint and maximum flow rate of the installation.

To select a dryer, first calculate the MDC (Minimum Drying Capacity) using the formula below then select a dryer from the flow rate table above with a flow rate equal to or above the MDC.

$$\text{Minimum Drying Capacity} = \text{System Flow} \times \text{CFIT} \times \text{CFAT} \times \text{CFMIP} \times \text{CFOD}$$

CFIT - Correction Factor Maximum Inlet Temperature

Maximum Inlet Temperature	°C	30	35	40	45	50	55	60	65
	°F	86	95	104	113	122	131	140	149
Correction Factor - 50Hz & 60Hz		0.81	1.00	1.23	1.49	1.82	2.44	2.63	2.94

CFAT - Correction Factor Maximum Ambient Temperature

Maximum Ambient Temperature	°C	20	25	30	35	40	45	50
	°F	68	77	86	95	104	113	122
Correction Factor - 50Hz & 60Hz		0.97	1.00	1.04	1.08	1.14	1.22	1.39

CFMIP - Correction Factor Minimum Inlet Pressure

Minimum Inlet Pressure	bar g	3	4	5	6	7	8	9	10	11	12	13	14
	psi g	44	58	73	87	100	116	131	145	160	174	189	203
Correction Factor - 50Hz & 60Hz		1.45	1.25	1.14	1.04	1.00	0.96	0.93	0.91	0.88	0.87	0.85	0.85

CFOD - Correction Factor Outlet Dewpoint

Outlet Dewpoint	°C	+3	+5	+7	+10
	°F	+37	+41	+45	+50
Correction Factor - 50Hz & 60Hz		1.00	0.90	0.81	0.69

Controllers' Main Functions

PSE Model	Function									
	Touch Screen	Compr. Air Temp.	Fault indication	Service Indication	Energy Saving Tech.	Alarm history	Data Log/ retrieve	Local Web Server	ModBus protocol	IoT
120-180		•	•	•	•	•			RTU RS485	opt.
220-350	3,5"	•	•	•	•	•	• Lan	•	RTU RS485 TCP/IP RJ45	opt.
460-1800	4,3"	•	•	•	•	•	• Lan & USB	•	RTU RS485 TCP/IP RJ45	•

Recommended Filtration

Model	Pipe Size BSPP or NPT	Dryer Inlet	Dryer Outlet
		General Purpose Pre-Filter	High Efficiency Post Filter
PSE 120	2"	AOPX040H	AAPX040H
PSE 140	2"	AOPX040H	AAPX040H
PSE 180	2"	AOPX045I	AAPX045I
PSE 220	2 ½"	AOPX050I	AAPX050I
PSE 260	2 ½"	AOPX055I	AAPX055I
PSE 300	2 ½"	AOPX055I	AAPX055I
PSE 350	2 ½"	AOPX055I	AAPX055I
PSE 460	DN100	AO070O	AO070O
PSE 520	DN100	AO070O	AA070O
PSE 630	DN100	AO070O	AA070O
PSE 750	DN150	AO075P	AA075P
PSE 900	DN150	AO075P	AA075P
PSE 1200	DN150	AO080P	AA080P
PSE 1500	DN200	AO085Q	AA085Q
PSE 1800	DN200	AO085Q	AA085Q

Filtration Performance	General Purpose Pre-filter	High Efficiency Post Filter
Filtration Grade	Grade AO	Grade AA
Filtration Type	Coalescing	Coalescing
Particle Reduction (inc water & oil aerosols)	Down to 1 micron	Down to 0.01 micron
Maximum Remaining Oil Aerosol Content at 21°C	≤0.5 mg/m ³ (≤0.5 ppm(w))	≤0.01 mg/m ³ (≤0.01 ppm(w))
Filtration Efficiency	99.925%	99.9999%

Weights & Dimensions

Model	Pipe Size BSPP or NPT	Dimensions						Weight	
		Height (H)		Width (W)		Depth (D)			
		mm	ins	mm	ins	mm	ins	kg	lbs
PSE 120	2"	1365	53.7	703	27.7	1150	45.3	205	452
PSE 140	2"	1365	53.7	703	27.7	1150	45.3	205	452
PSE 180	2"	1365	53.7	703	27.7	1150	45.3	210	463
PSE 220	2 ½"	1410	55.5	703	27.7	1151	45.3	260	573
PSE 260	2 ½"	1410	55.5	703	27.7	1151	45.3	262	578
PSE 300	2 ½"	1410	55.5	703	27.7	1151	45.3	264	582
PSE 350	2 ½"	1410	55.5	703	27.7	1151	45.3	270	595
PSE 460	DN100	2055	80.9	973	38.3	1287	50.7	380	838
PSE 520	DN100	2055	80.9	973	38.3	1287	50.7	380	838
PSE 630	DN100	2055	80.9	973	38.3	1287	50.7	420	926
PSE 750	DN150	2055	80.9	1205	47.4	1974	77.7	730	1609
PSE 900	DN150	2055	80.9	1205	47.4	1974	77.7	770	1698
PSE 1200	DN150	2055	80.9	1205	47.4	1974	77.7	850	1874
PSE 1500	DN200	2040	80.3	1517	59.7	2529	99.6	1070	2359
PSE 1800	DN200	2040	80.3	1517	59.7	2529	99.6	1210	2668

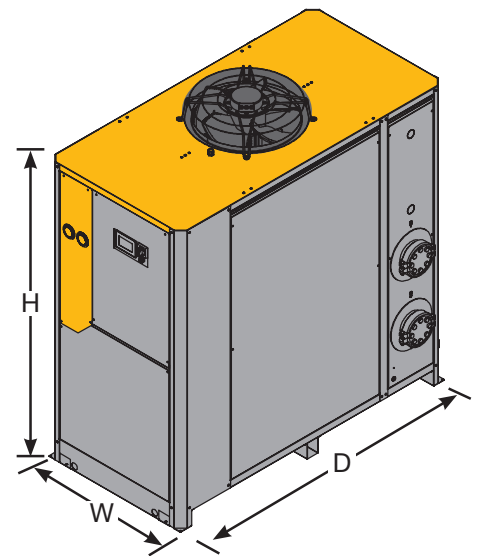

Quality Assurance / IP Rating / Pressure Vessel Approvals

Development / Manufacture	ISO 9001 / ISO 14001
Ingress Protection Rating	Indoor Use Only; IP44 from PSE120 to PSE180, IP54 from PSE220 to PSE1800
EU	Pressure vessel approved for fluid group 2 in accordance with the Pressure Equipment Directive 2014/68/EU
For use with Compressed Air Only	